

HYDRAULIC CIRCUIT 102B

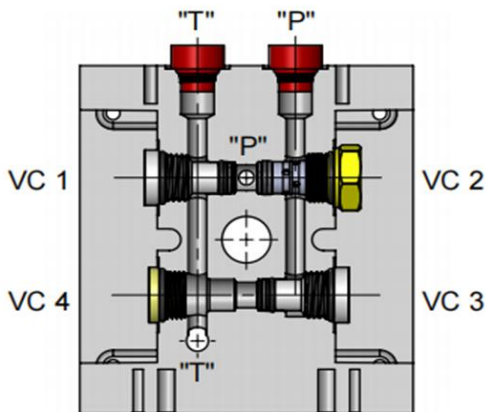

CAVITY 1: VALVE CAVITY PLUG
 CAVITY 2: CARTRIDGE CHECK VALVE
 CAVITY 3: VALVE CAVITY PLUG
 CAVITY 4: VALVE PLUG

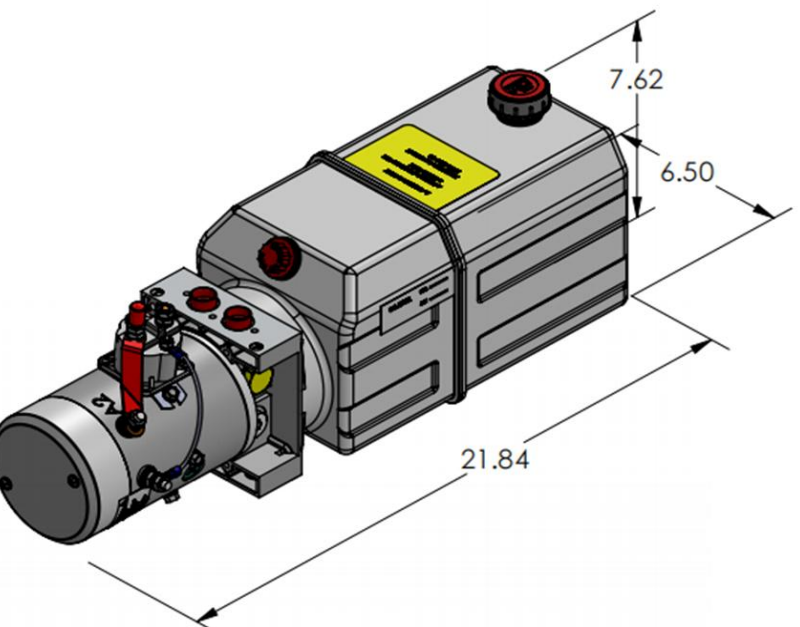

AS SHOWN:
 MOTOR: 12V DC
 MANIFOLD: UNIVERSAL MANIFOLD I®.
 PUMP: PL SERIES
 RESERVOIR: 6 QT PLASTIC

HYDRAULIC CIRCUIT 102B:

MOTOR

OD 3.0" 12V DC
 OD 4.5" 12/24V DC
 OD 5.0" 12/24V DC
 1/2 HP--5 HP AC

PUMP

PL	IN ³
0.6	0.0384
6.0	0.3681

RESERVOIR

PLASTIC RESERVOIR
 3 QT----14 QT

STEEL RESERVOIR
 1.5 QT----7 GALLON

MOUNTING

HORIZONTAL
 VERTICAL

MISC

DC START SWITCH