

HYDRAULIC CIRCUIT 104A

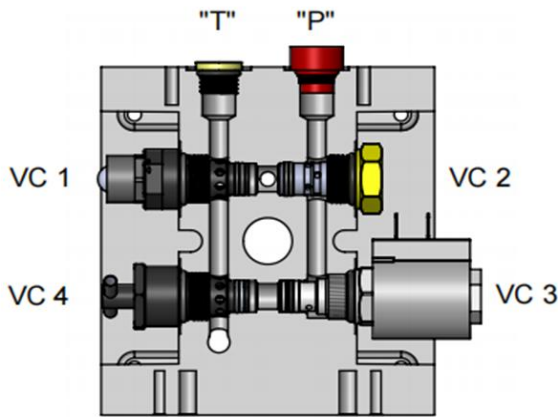

CAVITY 1: CARTRIDGE RELIEF VALVE
 CAVITY 2: CARTRIDGE CHECK VALVE
 CAVITY 3: NC 2W2P SOLENOID VALVE
 CAVITY 4: ADJUSTABLE FLOW CONTROL VALVE

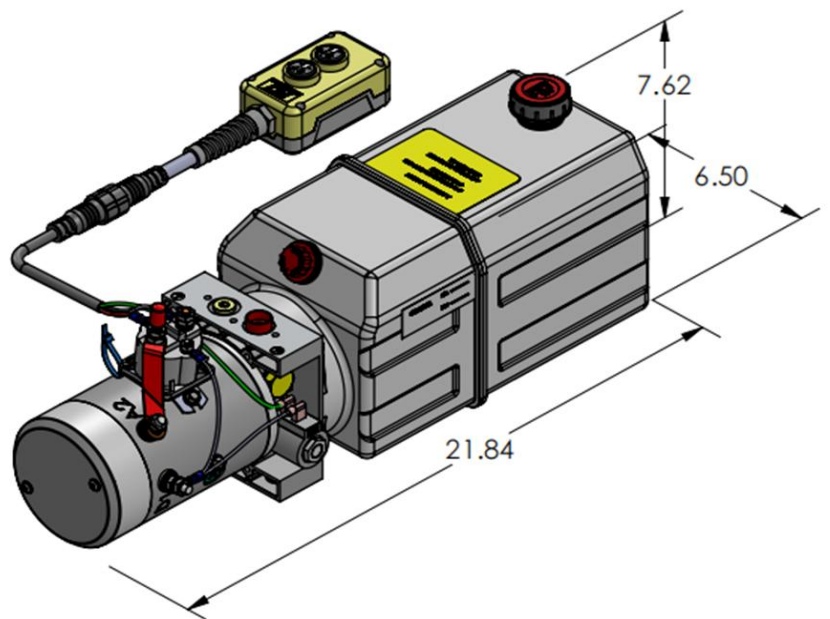

AS SHOWN:
 MOTOR: 12V DC
 MANIFOLD: UNIVERSAL MANIFOLD I®
 PUMP: PL SERIES
 RESERVOIR: 6 QT PLASTIC

HYDRAULIC CIRCUIT 104A:

MOTOR

OD 3.0" 12V DC
 OD 4.5" 12/24V DC
 OD 5.0" 12/24V DC
 1/2 HP--5 HP AC

PUMP

PL IN³
 0.6 0.0384
 | |
 | |
 6.0 0.3681

RESERVOIR

PLASTIC RESERVOIR
 3 QT----14 QT
 STEEL RESERVOIR
 1.5 QT----7 GALLON

MOUNTING

HORIZONTAL
 VERTICAL

MISC

DC START SWITCH
 REMOTE PENDANT