

**HYDRAULIC CIRCUIT 104B**

**DESCRIPTION:**

Universal Manifold I, Hydraulic Circuit 104B.  
 Base lift, check, and lowering with fully adjustable pressure compensated return flow power unit.  
 Motor, Universal Manifold I® (with cartridge relief valve, cartridge check valve, cartridge NC 2 way valve, and pressure compensated adjustable flow control valve), Pump, Tank.  
 "P" & "T" SAE #6(9/16-18) O-ring ports.

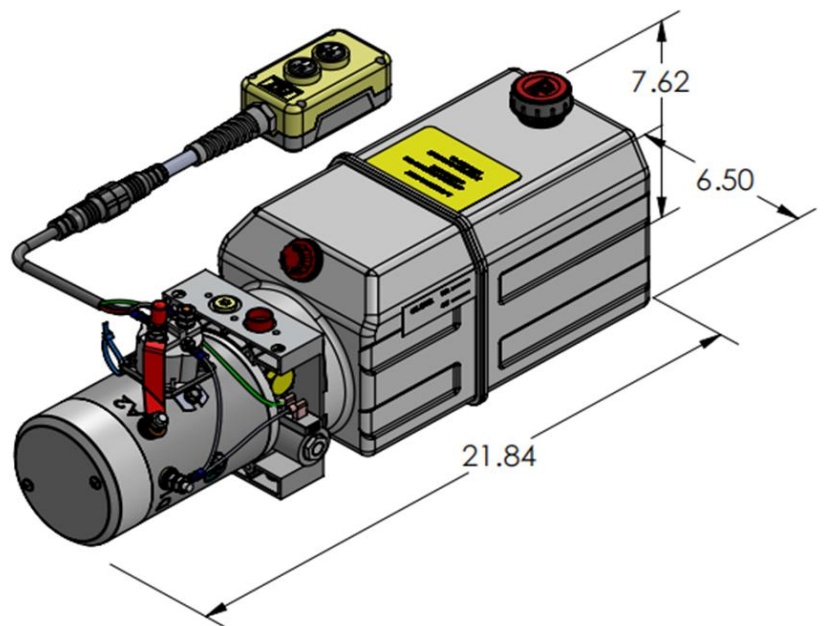
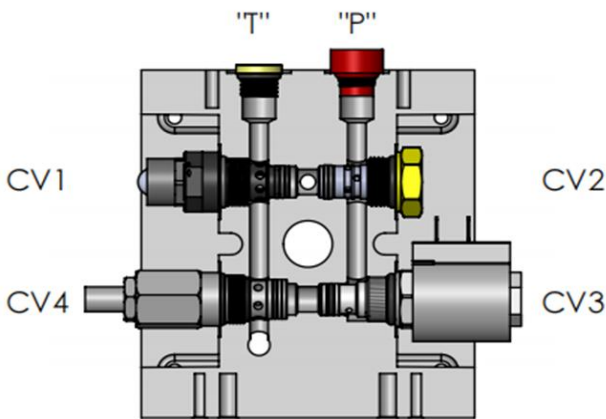

CAVITY 1: CARTRIDGE RELIEF VALVE  
 CAVITY 2: CARTRIDGE CHECK VALVE  
 CAVITY 3: NC 2W2P SOLENOID VALVE  
 CAVITY 4: PRESSURE COMPENSATED  
 ADJUSTABLE FLOW CONTROL  
 VALVE

AS SHOWN:  
 MOTOR: 12V DC  
 MANIFOLD: UNIVERSAL MANIFOLD I®.  
 PUMP: PL SERIES  
 RESERVOIR: 6 QT PLASTIC

**HYDRAULIC CIRCUIT 104B:**

**MOTOR**

OD 3.0" 12V DC  
 OD 4.5" 12/24V DC  
 OD 5.0" 12/24V DC  
 1/2 HP--5 HP AC

**PUMP**

PL IN<sup>3</sup>  
 0.6 0.0384  
 | |  
 6.0 0.3681

**RESERVOIR**

PLASTIC RESERVOIR  
 3 QT----14 QT  
 STEEL RESERVOIR  
 1.5 QT----7 GALLON

**MOUNTING**

HORIZONTAL  
 VERTICAL

**MISC**

DC START SWITCH  
 REMOTE PENDANT