

HYDRAULIC CIRCUIT 110

DESCRIPTION:

Universal Manifold II, Hydraulic Circuit 110. Double acting circuit for power up, power down operation. Motor, Universal Manifold II® (with cartridge relief valve, 4w2p valve, KTI proprietary load holding valve), Pump, Tank. "A" & "B" SAE #6(9/16-18) O-ring ports.

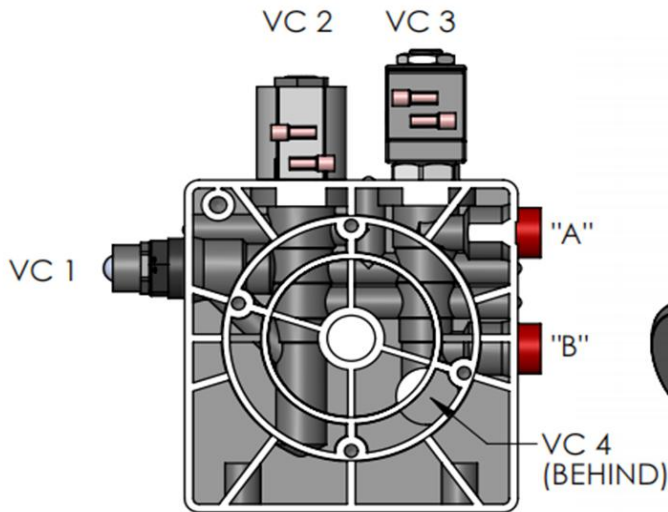

CAVITY 1: CARTRIDGE RELIEF VALVE
 CAVITY 2: 4W2P DIRECTION VALVE
 CAVITY 3: PROPRIETARY LOAD HOLDING VALVE
 CAVITY 4: PLUG

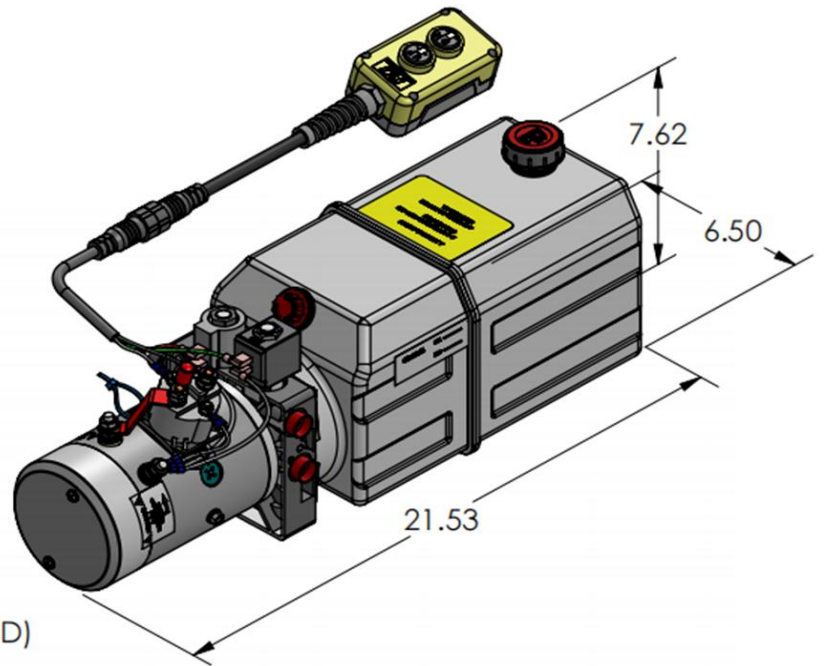

AS SHOWN:
 MOTOR: 12V DC
 MANIFOLD: UNIVERSAL MANIFOLD II®.
 PUMP: PL SERIES
 RESERVOIR: 6 QT PLASTIC
 2 BUTTON REMOTE PENDANT W/QD

HYDRAULIC CIRCUIT 110:

MOTOR
 OD 3.0" 12V DC
 OD 4.5" 12/24V DC

PUMP
 PL IN³
 0.6 0.0384
 | |
 6.0 0.3681

RESERVOIR
 PLASTIC RESERVOIR
 3 QT----14 QT
 STEEL RESERVOIR
 1.5 QT----7 GALLON

MOUNTING
 HORIZONTAL
 VERTICAL

MISC
 DC START SWITCH
 REMOTE PENDANT