

HYDRAULIC CIRCUIT 111

DESCRIPTION:

Universal Manifold II, Hydraulic Circuit 111.
Double acting circuit for power up, power down operation.
Motor, Universal Manifold II® (with cartridge relief valve, 4w2p valve, KTI proprietary load holding valve, secondary relief valve), Pump, Tank.
"A" & "B" SAE #6(9/16-18) O-ring ports.

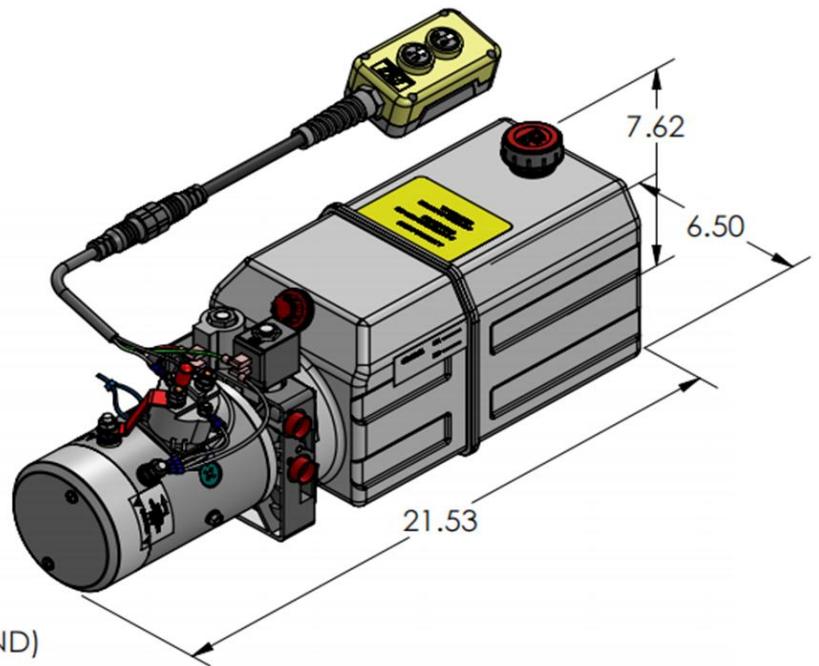
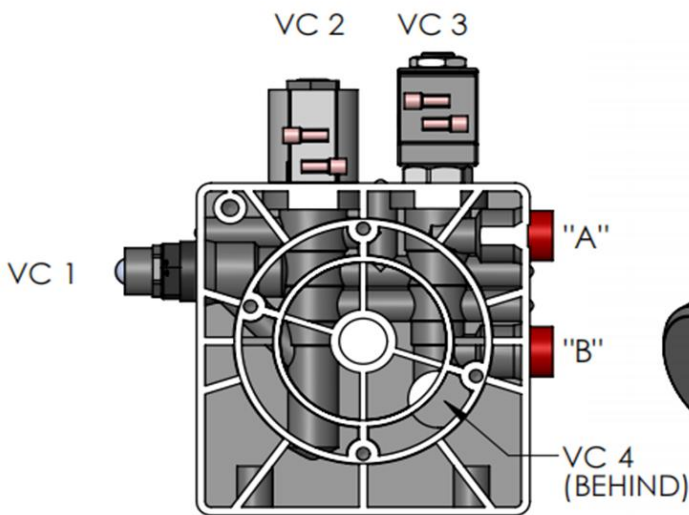

CAVITY 1: CARTRIDGE RELIEF VALVE
CAVITY 2: 4W2P DIRECTION VALVE
CAVITY 3: PROPRIETARY LOAD HOLDING VALVE
CAVITY 4: 2ND RELIEF VALVE

AS SHOWN:
MOTOR: 12V DC
MANIFOLD: UNIVERSAL MANIFOLD II®.
PUMP: PL SERIES
RESERVOIR: 6 QT PLASTIC
2 BUTTON REMOTE PENDANT W/QD

HYDRAULIC CIRCUIT 111:

MOTOR
OD 3.0" 12V DC
OD 4.5" 12/24V DC

PUMP
PL IN³
0.6 0.0384
| |
6.0 0.3681

RESERVOIR
PLASTIC RESERVOIR
3 QT----14 QT

STEEL RESERVOIR
1.5 QT----7 GALLON

MOUNTING
HORIZONTAL
VERTICAL

MISC
DC START SWITCH
REMOTE PENDANT